



5G 3GPP RELEASE 16

The Impact on 5G Monetisation

5G CORE NETWORK

Release 16 Enhancements

R16 is the reference release for 5G Core

[FIND OUT MORE](#)
PAGE 5



Turning 5G Vision into Reality

The importance of meeting 5G standards

[FIND OUT MORE](#)
PAGE 4

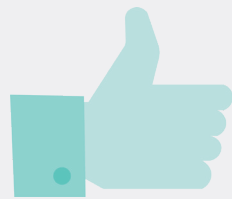

New Business Models Enabled for Service Providers by Release 1

New markets, new pricing models and new business opportunities

[FIND OUT MORE](#)
PAGE 11

Release 16 New Capabilities

New features that go beyond Enhanced Mobile Broadband

[FIND OUT MORE](#)
PAGE 7



Enabling New Revenue Opportunities with Network Embedded Services

Putting the 5G network centre stage as business driver

[FIND OUT MORE](#)
PAGE 14

The Impact on 5G Monetisation

Opportunities to develop new revenue streams with R16 features

[FIND OUT MORE](#)
PAGE 9



5G AND THE 'BIG PICTURE' VIEW

“This report was based on research and workshops with government ministers and C level executives from many leading telecoms companies”

In January 2021 the World Economic Forum published a report which summarised their 5G Outlook Series and focused on how 5G will enable inclusive long-term opportunities. This report highlighted the role 5G can play as societies and economies bounce back from the Covid-19 pandemic.

This report was based on research and workshops with government ministers and C level executives from many leading telecoms companies. The key points in this report, listed below, highlight the fact that 5G is not just about telecoms any more. It can be an enabler of economic and societal change.



WORLD
ECONOMIC
FORUM

WORLD ECONOMIC FORUM: FIVE KEY TAKEAWAYS ON 5G

1. In the 2020s and beyond a robust 5G infrastructure will be foundational to both inclusive economic growth and competitiveness
2. 5G has the potential to democratize computing, helping to close digital divides
3. Public-private partnerships are essential to success and broad-based gains
4. To benefit from 5G, countries urgently require a clear strategy for cross-industry investment and policy
5. 5G is a general-purpose technology enabler, unlocking the potential of cloud, artificial intelligence (AI) and edge computing

With regards to the economic impact of 5G there's various reports forecasting significant revenue from 5G for service providers and the wider ICT industry. In November 2020 research firm Omdia published a research paper that said that by 2030 the 5G consumer market could be worth US \$31 trillion in 'cumulative consumer revenues for the ICT industry'. Of this figure service providers could get \$3.7 trillion from connectivity and selling digital services. Juniper also recently published figures that forecast by 2025, 5G revenues for service providers will be approximately US\$357bn (Operator Revenue Strategies: Future Market Outlook, Business Models & Emerging Opportunities 2020-2025, published October 2020).

TURNING THE 'BIG PICTURE' VIEW INTO REALITY: THE NEED TO UNDERSTAND AND MEET THE 5G STANDARDS

At its heart 5G is built using telecoms and IT network technology and standards

It can drive many advances in how businesses, societies and individuals work, interact and communicate but at its heart there are standards and specifications developed by the 3GPP (3rd Generation Partnership Project). Understanding the 3GPP releases provides a view on what is possible with each release of 3GPP standards and the subsequent release of 3GPP compliant systems that 5G networks and services are built on.

In summer 2020 3GPP Release 16 was completed. Described as 'the next stage of 5G' Release 16 brings a lot of new enhancements and new features for 5G. This paper examines the following:

- Release 16 Enhancements
- Release 16 New Capabilities
- The Impact on 5G Monetisation
- New Business Models enabled for Service Providers by Release 16
- Enabling New Revenue Opportunities with Network Embedded Services



RELEASE 16 ENHANCEMENTS:

Release 16 is an important release for 5G. Many operators will use it as the reference release for their first adoption of a 5G Core (5GC). Release 16 as the new core network will deliver a valuable set of enhancements to the Release 15 capabilities. These include the following:

ENHANCEMENT OF NETWORK SLICING

Network slicing is a key 5G feature that enables an operator to support specific use cases with a dedicated set of network resources matched with a service level agreement for the use case. Network slicing is enhanced in Release 16 with support for network slicing interworking from EPC to 5GC; and authentication and authorization controls specific to the slice

ENHANCEMENTS FOR THE SERVICE BASED ARCHITECTURE (SB

Service discovery and service routing are enhanced in Release 16. This includes the introduction of a new service communication proxy (SCP) network function.

ENHANCEMENTS TO THE NETWORK AUTOMATION

The 5G core network supports the application of analytics to provide intelligent automation of the network, In Release 16 the set of use cases that are proposed for the Network Data Analytics Function (NWDAF) is widely expanded to leverage artificial intelligence directly within the network domain.

REDUNDANCY ENHANCEMENTS TO ENABLE URLLC SERVICES

5G will support services that require ultra-reliability. Release 16 introduces support for end to end redundancy of the data paths for 5G applications using URLLC services.

ENHANCEMENT OF LOCATION SERVICES

The 5G supports the retrieving location and velocity of a UE registered with the 5GC. This functionality is further enhanced in Release 16 to support new features such as roaming, privacy management and exposure services.

RELEASE 16 ENHANCEMENTS:

RADIO CAPABILITIES SIGNALING OPTIMIZATION

This enhancement covers the signaling of UE Radio capabilities within the network and the management of the required mappings to achieve this. This includes the introduction of a new UE Capability Management Function (UCMF).

TOPOLOGY ENHANCEMENT FOR FLEXIBLE DEPLOYMENT OF SMFS AND UPFS

The distributed nature of the 5GC architecture is further enhanced to enable more complex scenarios for interactions between SMFs and UPFs. This includes the introduction of a new Intermediate SMF (I-SMF) network function.

ADVANCED V2X SERVICES OVER 5G

Release 16 has enhancements to provide transport services to facilitate vehicular communications for Vehicle-to-Everything (V2X) services. This will enable features such as intersection safety and vehicle platooning for self-driving cars.

PROTOCOL ENHANCEMENTS FOR NEW VERTICALS

Release 16 enhancements build upon the architecture from Release 15. These enhance the system to provide improved services to a broader set of verticals such as public safety and railway systems.



RELEASE 16 NEW CAPABILITIES:

SUPPORT FOR ACCESS TRAFFIC STEERING, SWITCH AND SPLITTING

This feature introduced in Release 16 allows fine grained traffic steering across multiple accesses. The feature introduces the concept of a Multi Access PDU session. This allows for data traffic to be served over multiple accesses e.g. 3GPP access, trusted and untrusted non 3GPP access.

SUPPORT FOR AN INTEGRATED ARCHITECTURE ENABLING WIRELINE ACCESS CONNECTIVITY TOWARDS A 5GC VIA 3GPP INTERFACES AND PROTOCOLS

Release 16 provides native support for wireline access networks. The architecture reference model now includes wireline access by incorporating support for fixed network residential gateways (FN-RGs) and a Wireline Access Gateway Function (W-AGF).

COMMON CAPABILITIES FOR A SERVICE ENABLER ARCHITECTURE LAYER

A new service enabler architecture layer (SEAL) that supports vertical applications by providing a common set of services e.g. group management, configuration management, location management.

The above summary of enhancements and the new capabilities shows the importance of Release 16 on 5G.

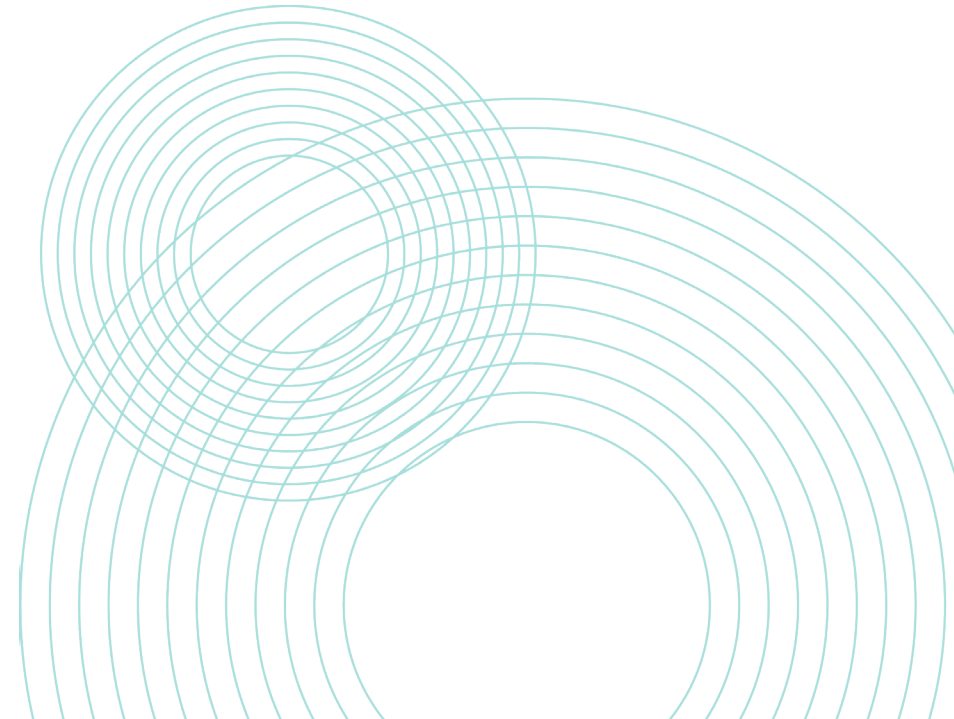

THE IMPACT ON 5G MONETISATION

NETWORK SLICE MANAGEMENT CHARGING

Charging for Network Slice Instance NSI allocation, modification and deallocation. This is based on interactions with an OAM network slice provisioning service e.g. within an NSMF.

CHF-CONTROLLED QUOTA MANAGEMENT

Adds the ability for a CHF able to instruct an SMF to suspend and to resume quota management for a particular rating group.

CHARGING ASPECTS FOR 5WWC

Adds wireless-wireline convergence support for the charging aspects related to 5G enabled wireline access networks.

CHARGING ASPECTS FOR ENHANCED DEPLOYMENT ARCHITECTURES

Adds support for charging related to the topology enhancement for flexible deployment of SMFs and UPFs described above, for example when an I-SMF is in the call path.

CHARGING ASPECTS OF ACCESS TRAFFIC STEERING, SWITCH AND SPLITTING

This work specifies the charging aspects for the support of Access Traffic Steering, Switching and Splitting (ATSSS) in the 5G. It enables charging for Multi Access-PDU (MA-PDU) sessions over one 3GPP access and one non-3GPP access.



NEW BUSINESS MODELS ENABLED FOR SERVICE PROVIDERS BY RELEASE 16

It is anticipated that Release 16 will be an opportunity for new verticals to embrace the capabilities of the 5G network.

New verticals will need to be charged differently than the traditional subscriber based consumption models of previous releases.

For example for IoT type scenarios the value may be based on the number of connected devices, or the location from where the devices connect to the network, or even the mobility profile associated with a particular device. The new AMF related charging features in Release 16 will be useful in enabling charging for these types of scenarios.

Other verticals such as mission critical services or V2X type services will rely on application servers to interact with the 5G network through exposed network service enablers (i.e. via APIs). The new NEF related charging features in Release 16 will be useful in enabling charging for these types of scenarios.

One of the most important features of the 5G network is the Network Slicing feature and Release 16 has enhanced this feature. Operators are keen to be able offer Network Slices as service (NSaaS) in a B2B2X model as described in 3GPP TS 28.530 with the following Figure 1:

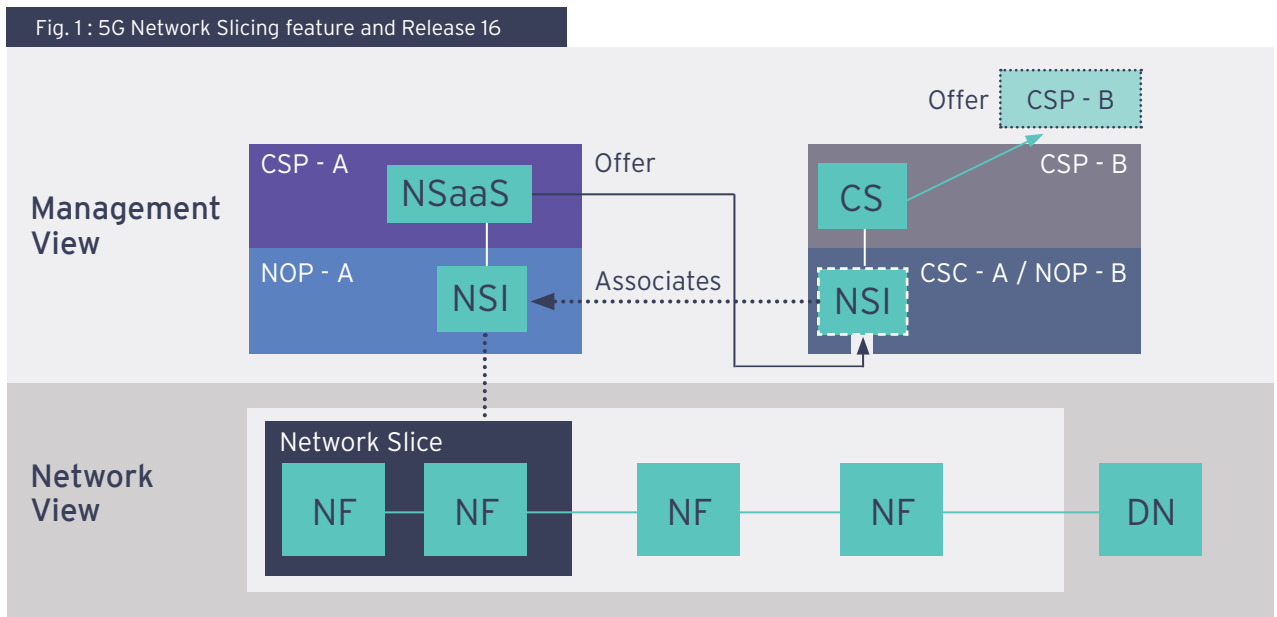

There are potentially many actors (e.g. Communication Service Provider, Communication Service Customer, Network Operator) in the NSaaS ecosystem and the ability to offer, measure and charge for network slices requires new charging capabilities to be delivered in Release 16.

NEW BUSINESS MODELS ENABLED FOR SERVICE PROVIDERS BY RELEASE 16

The new charging architecture for NSaaS charging is specified within TS 28.202. The architecture is not fully finalized at this stage but the current proposed architecture looks promising. It is depicted as follows in Figure 2 and Figure 3:

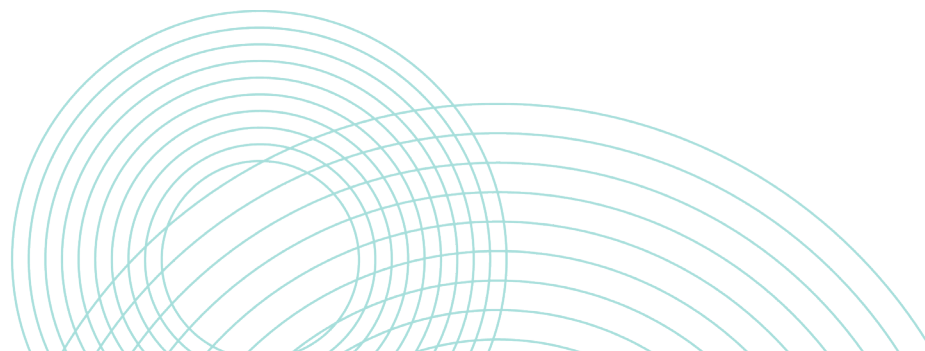
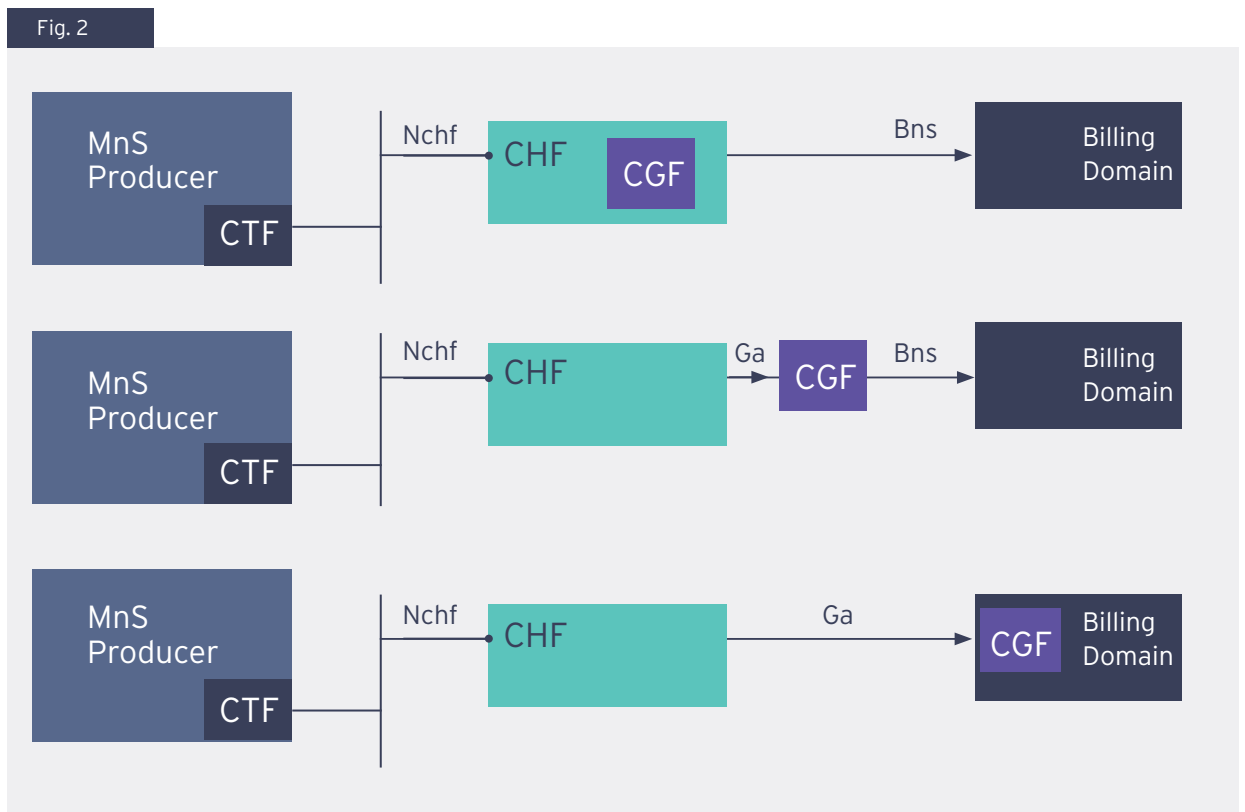

NEW BUSINESS MODELS ENABLED FOR SERVICE PROVIDERS BY RELEASE 16

Fig. 3

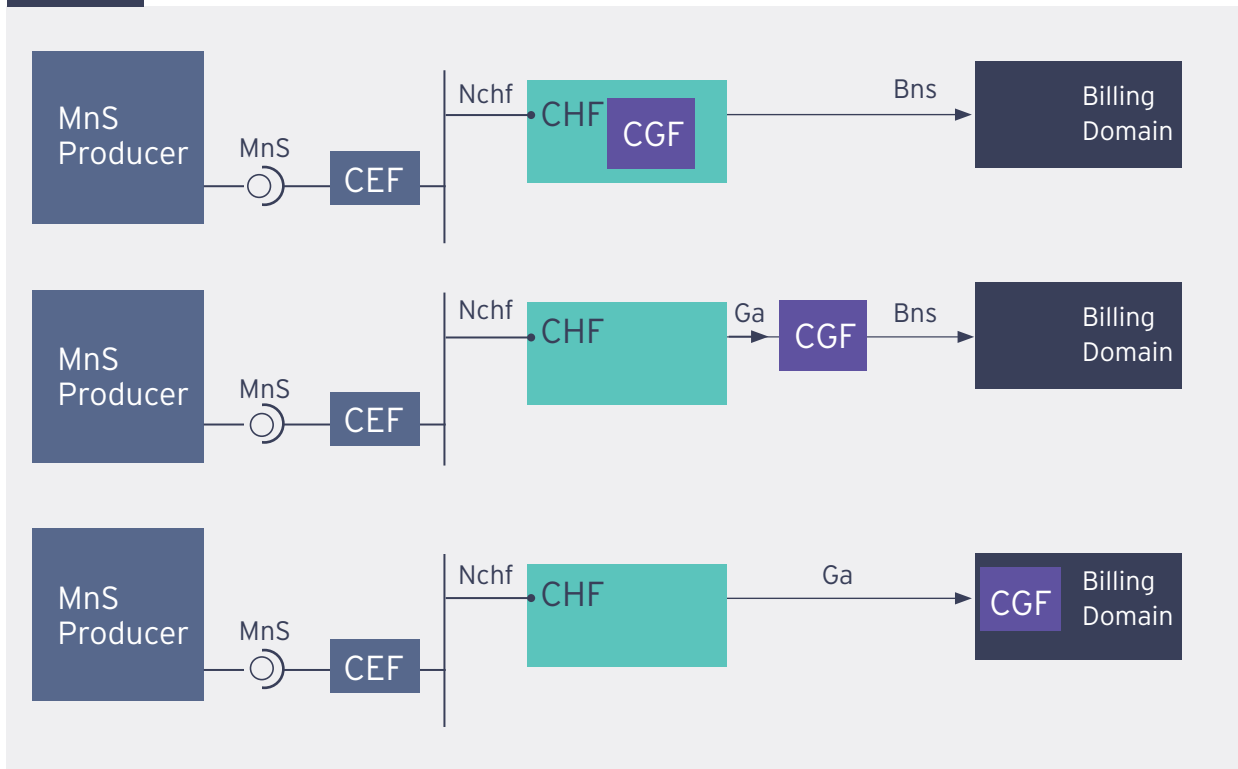

The service producer is typically a 3GPP OAM Provisioning Management Service (MnS).

There are two scenarios covered by the architecture:

1. A charging trigger function (CTF) is coupled with the MnS producer. The CTF directly consumes charging services of the CHF (as shown above in Figure 2).
2. An external eCTF interacts with both the MnS and CHF. The eCTF transfers network slicing management events to the CHF (as shown above in Figure 3).

As can be seen from this paper there are a lot of new elements in 5G charging. Additional features like network slicing charging open new opportunities and for mobile operators to grow their business.

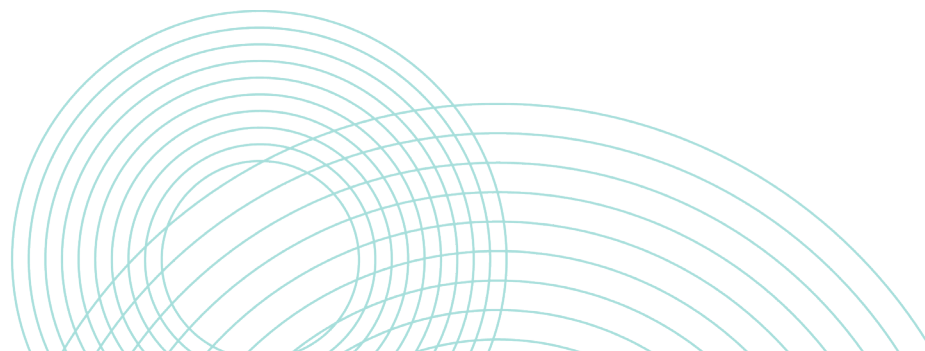

ENABLING NEW REVENUE OPPORTUNITIES WITH NETWORK EMBEDDED SERVICES

R16 and the introduction of new capabilities such as slicing enables operators to start to monetise the 5G networks. It enables them to go way beyond selling connectivity. There has been research for both the enterprise and consumer markets that show that customers will pay a premium for 5G services that come with a guaranteed Quality of Service. Mission critical applications such as 5G healthcare and remote surgery can use slices with a higher quality of service than standard connectivity. These services where network attributes (latency, QoS, etc) are a fundamental part of the offer are called network embedded services

With the emergence of network embedded services and the subsequent monetisation of the 5G network, there will be closer scrutiny on how service providers develop, manage and monetise 5G services. Clearly the network functions in 5G need to be very tightly integrated into BSS - after all, the network attributes are not just a means of delivering a service, but they are now part of the service. As such we'll see the emergence of a 5G Value Plane that bridges IT & business functions and the 5G network. Central to this 5G Value Plane are the service catalog in BSS as well as 5G Policy (PCF) and Charging (CHF, CCS).

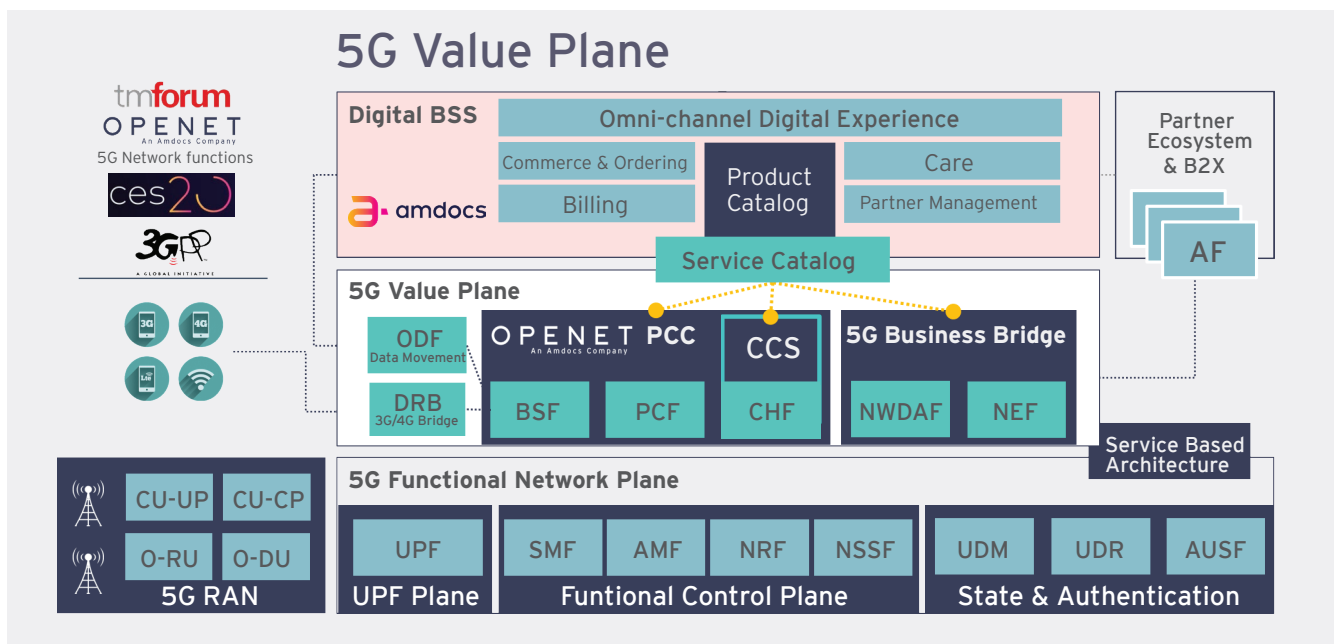

With 5G, policy is no longer just a network control mechanism. It is used to build and deliver 5G services. It's like the brain of the network and is integrated with 5G charging so that different offers with different network characteristics (e.g. guaranteed QoS) will have different pricing and charging rules applied. 5G policy and charging functions in the 5G Value Plane need to be integrated to service catalogs in existing BSS stacks and also to the 5G network, thus providing a bridge between business & IT, and the 5G network. This provides the agility needed for service providers to quickly develop, launch, manage and monetise new 5G offers. This will open new revenue streams, enable the development of new business models and dramatically improve the ability to monetise the 5G network.

ABOUT OPENET:

Openet, an Amdocs company, is a leading software and services provider to communications companies. Our deep domain expertise & understanding of complex systems, underpinned by the tenacity and determination of our people, enable us to radically transform how our customers do business, providing best in class digital and 5G business support systems.

In an industry where the only constant is change, our open and innovative technology is built for change. For the last 20 years we have helped the world's most innovative communications companies manage and monetise their business and evolve from communications companies to digital service providers. This gives our customers the power to enter new markets, open new revenue streams and increase profitability.

Openet. Built for Change.

OPENET PRODUCTS:

Openet Charging:

Real-time convergent charging for digital and 5G services

Openet Policy:

Network policy control for next gen fixed, mobile and converged networks

Openet Data:

Data management, data processing and data governance solution designed to collect and manage data at 5G volumes in real-time

Openet Digital Platform:

End to end Digital BSS/OSS stack containing Openet & our partners' products

Openet Forge:

The digital enablement toolkit which contains Openet's library of microservices, upon which all Openet products are built

DELIVERING BUSINESS VALUE:

40%

Reduction in time to market for new offer creation

28%

Uplift in offer uptake

11%

Increase in mobile data ARPU

41%

Increase in mobile data revenues

OPENET PRODUCT PORTFOLIO

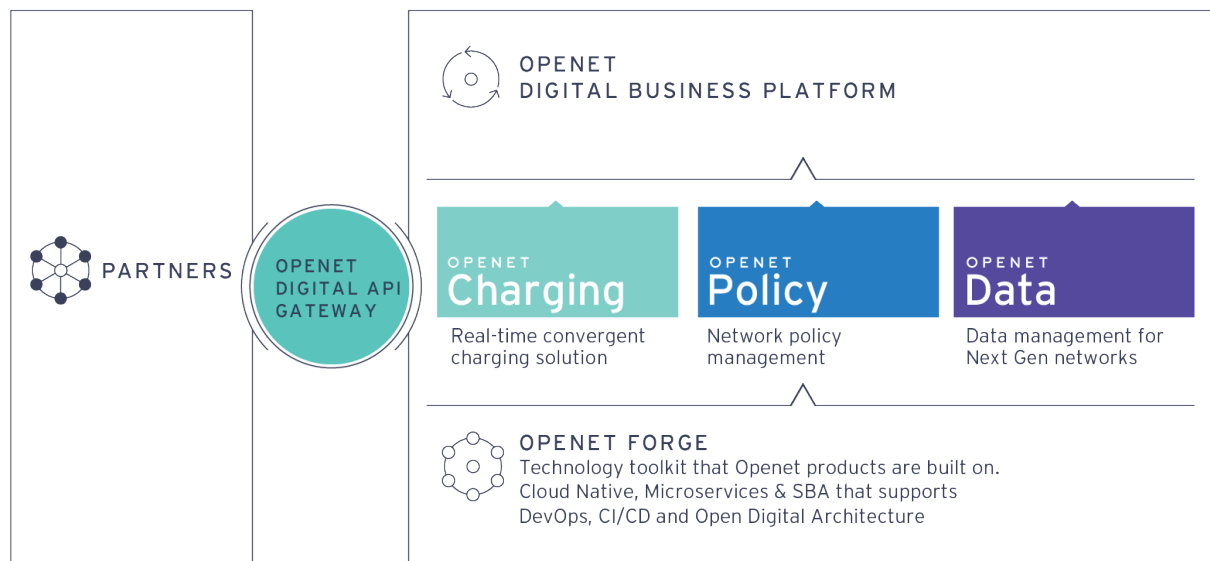

OPENET
An Amdocs Company

OUR CUSTOMERS



CONTACT

IRELAND	USA	MAYLAISIA	BRAZIL
+353 1 620 4600	+1 703 480 1820	+60 3 2 289 8500	+55 11 2395 7200

BUILT FOR CHANGE

WWW.OPENET.COM | INFO@OPENET.COM